

# DELTA SD4

DOUBLE SEAL VALVES



SPX is highly committed to delivering sustainable solutions, which exceed customer expectations in value and return through a focus on.

- Waste prevention and loss reduction
- Reuse of resources
- Improved value of raw materials
- Water and energy reduction
- Product safety and security
- Social responsibility

It's hard to find a more comprehensive portfolio of processing equipment anywhere else. Many of our designs incorporate patented features and our research and development efforts continue to produce ground breaking technologies. When you specify our equipment you get more than a product – you get a partner.

Engineering excellence, allied to stringent quality control, ensures that SPX's unrivalled range of APV products complies with the highest international standards for hygiene. In the light of growing pressure worldwide to deliver safe, high quality food, all SPX products are designed for easy cleanability, while minimizing the use of valuable resources, such as energy. The APV product portfolio includes a wide range of pumps, valves, heat exchangers, mixers and homogenisers designed for use in the food, dairy and brewing industries, as well as in chemical, healthcare, pharmaceutical processing and heavy industries.

# DELTA SD4 Double Seal Valves

## PRODUCT BENEFITS AND FEATURES

### SAFE SEPARATION OF INCOMPATIBLE MEDIA

With two serial seat seals and a separation cavity, the DELTA SD4 valves are designed for safe media separation.

### EXCELLENT HYGIENIC FEATURES

DELTA SD4 valves have excellent hygienic characteristics due to a number of design features:

- Ball-shaped housing without sump or dome
- Crevice-free sealing
- Leakage discharge valves enabling drainage as well as cleaning of neutral cavity

### CIP/SIP CLEANING OF LEAKAGE CAVITY

The DELTA SD4 valves have leakage discharge valves to drain the neutral area between the seals. The leakage discharge valves are used for supply and discharge of cleaning media, which enables CIP and SIP cleaning of the neutral area. Leakage valves and actuator are controlled by the same solenoid valve. Therefore, additional control is not required.

### MULTIPLE DESIGNS AVAILABLE, INCL. ASEPTIC

DELTA SD4 valves are available in a shut-off, a change-over and a tank-outlet design. Furthermore, the valves are available in an aseptic design with a supported flat TFM membrane.

### LONG SEAL LIFE

Sealings designed with metallic stop ensure limited elastomer compression and, consequently, avoidance of sealing overstress.

Moulded elastomer profile seals with clear identification markings ensure prompt and failsafe identification of seals during maintenance.

### MAINTENANCE-FRIENDLY

Only one hexagonal nut outside the product area ensures quick and easy service of the valve.

Flanged valve body closure for safe and controlled disassembly and assembly of valve insert.

# Typical product applications

## THEORY OF OPERATION

The DELTA SD4 valves are used for safe separation of incompatible media. Safe media separation is provided by a design with two seat seals.

A ring-shaped leakage chamber is arranged between the two seals. It is forcibly closed or opened to the atmosphere by the two leakage discharge valves.

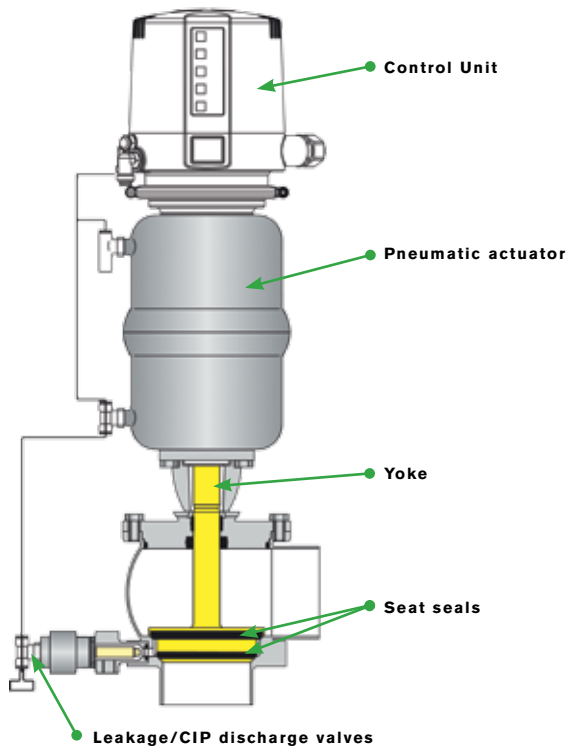

In case of damage of the seat seals, the leakage will be drained via the leakage valves to the atmosphere and indicated.

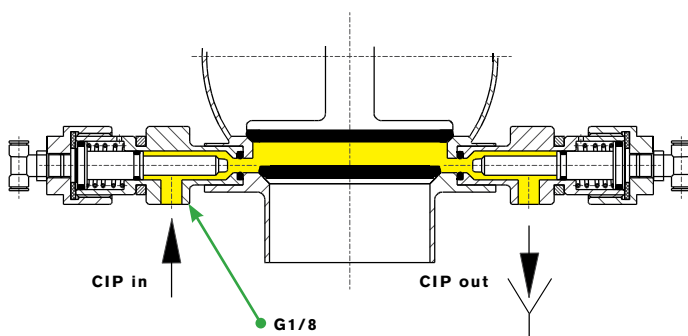

Cleaning of the leakage chamber is undertaken via the leakage valves. The cleaning liquid is supplied via one leakage valve and discharged to the atmosphere via the second one.

The directed flow of the cleaning liquid provides for a perfect cleaning of the whole leakage chamber.

DELTA SD4 valves are typically used to connect the CIP supply line to the product processing line and to connect the manifold to the CIP return line within the following sectors:

### Beverage



### Food



### Dairy



### Pharmaceutical



### Chemical



# Product Specifications

DELTA SD4 DESIGNS AVAILABLE*	
DELTA SD4	STANDARD SHUT-OFF VALVES
DELTA SD4 LONG STROKE	LONG STROKE SHUT-OFF VALVES
DELTA SDMS4	ASEPTIC VERSION WITH SUPPORTED FLAT TFM DIAPHRAGM
DELTA SDU4	CHANGE-OVER VERSION
DELTA SDT4	TANK OUTLET VERSION

\*Combinations of the designs listed are also available, e.g. aseptic tank outlet version (DELTA SDTMS4) and aseptic change-over valves (DELTA SDMSU4).

MATERIALS	
PRODUCT WETTED METALLIC PARTS	1.4404 / AISI 316L
OTHER METALLIC PARTS	1.4301 / AISI 304
SEALS (FDA COMPLIANT)	EPDM <b>OPTIONAL:</b> HNBR, FPM, VMQ
MEMBRANE, DELTA SDMS4	PTFE

TECHNICAL DATA	
FUNCTIONALITY	SHUT-OFF CHANGE-OVER
SIZES	DELTA SD4, SDU4, SDMS4, SDT4: DN25 TO DN100 1" TO 4"
MAX. LINE PRESSURE	DELTA SD4, SDU4, SDMS4, SDT4: 10 BAR
MAX. OPERATING TEMPERATURE	EPDM, HNBR, VMQ, FPM: 135°C VMQ AND FPM SHOULD NOT BE USED WITH HOT WATER/STEAM
MAX STERILIZATION TEMPERATURE (SHORT TERM)	EPDM, HNBR, VMQ, FPM: 140°C VMQ AND FPM SHOULD NOT BE USED WITH HOT WATER/STEAM
AIR CONNECTION, HOSE	6x1 MM
MIN. CONTROL AIR PRESSURE	6 BAR
MAX. CONTROL AIR PRESSURE	8 BAR
CONNECTION, LEAKAGE DISCHARGE VALVES	G 1/8"
ACTUATOR	STAINLESS STEEL, MAINTENANCE-FREE AND DELIVERED WITH A FIVE-YEAR GUARANTEE
CONNECTIONS	WELD-ENDS ARE STANDARD.

## VALVE HOUSING VARIANTS:



DELTA SD41



DELTA SD42



DELTA SDE43



DELTA SDE44



DELTA SDT41



DELTA SDT42



DELTA SDU45



DELTA SDU46



DELTA SDU47



DELTA SDU48

## Options & Accessories

DELTA SD4 valves are available with proximity switch holder or a control unit.

### PROXIMITY SWITCH HOLDER

Proximity switches to signal the final position of the valve seat can be mounted to the proximity switch holders if required.

### DELTA CU CONTROL UNIT

The DELTA CU control units, used on various APV valve lines, are also available with the DELTA SD4 valves. The control unit operates as interface between process control and valve and controls the electric and pneumatic signals.

APV DELTA CU control units are very robust, easy to maintain, and designed to operate in tough environments. Signal data are easily visible on an exterior LED (electronic lights).

DELTA CU control units are available with or without a NOT element. A NOT element provides automatic air assist to the back side of the piston to increase product holding pressure. DELTA SD4 valves are typically delivered with DELTA CU41N control units, including NOT element, to provide increased stem holding pressure.

### INTERFACE OPTIONS

- DELTA CU4 Direct Connect (hard wire)
- DELTA CU4 AS-Interface, 31 or 62 slaves
- Profibus and DeviceNet (DELTA CU3)

### POSITION INDICATION

2 internal feedback sensor switches for valve open/valve closed position detection

### SOLENOID VALVES

- 1 Solenoid

### PROTECTION CLASS

- IP67
- NEMA 6



# Dimensional Data

## DELTA SD41, SD42

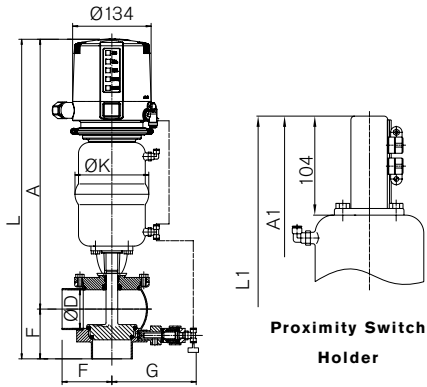

Valve with DELTA CU4

VALVE SIZE	A MM	A1 MM	ØD MM	F MM	G MM	ØK MM	L MM	L1 MM	WEIGHT KG
DN25	409	337	26	50	126	86	459	387	5.4
DN40	415	343	38	67	129	86	482	399	6.1
DN50	452	380	50	72	133	126	524	442	8.3
DN65	460.5	388	66	85	145	126	545.5	459	10.0
DN80	512.5	441	81	98	153	189	610	520	16.5
DN100	522.5	451	100	111	162	189	633.5	540	18.3
1"	407	335	22.6	50	126	86	457	383	5.4
1.5"	413	341	34.9	67	129	86	480	395	6.1
2"	451	379	47.6	72	133	126	523	440	8.3
2.5"	457.5	385	60.3	85	142	126	542.5	453	9.5
3"	508.5	436	72.9	100	148	189	598.5	510	15.6
4"	520.5	449	97.6	111	162	189	631.5	533	18.3

## DELTA SDE43, SDE44

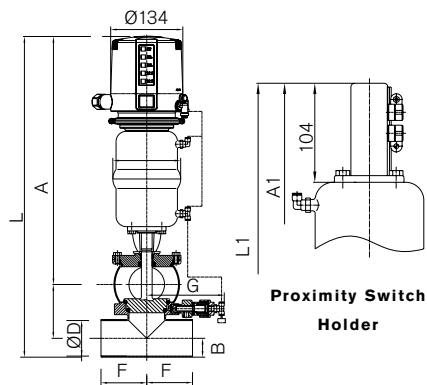

Valve with DELTA CU4

VALVE SIZE	A MM	A1 MM	B MM	ØD MM	F MM	G MM	H MM	ØK MM	L MM	L1 MM	WEIGHT KG
DN25	409	337	14.5	26	50	126	60	86	483.5	411.5	5.8
DN40	415	343	20.5	38	67	129	72	86	507.5	435.5	6.6
DN50	452	380	26.5	50	72	133	84	126	562.5	490.5	8.8
DN65	460.5	388	35.0	66	85	145	100	126	595.5	523.0	10.5
DN80	512.5	441	42.5	81	98	153	115	189	670.0	598.5	17.1
DN100	522.5	451	52.0	100	111	162	134	189	708.5	637.0	18.9
1"	407	335	12.5	22.6	50	126	56.6	86	476.1	404.1	5.8
1.5"	413	341	19.0	34.9	67	129	68.9	86	500.1	428.9	6.6
2"	451	379	25.4	47.6	72	133	81.6	126	558.0	486.0	8.8
2.5"	457.5	385	31.7	60.3	85	142	94.3	126	583.5	511.1	10.1
3"	508.5	436	38.0	72.9	100	148	106.9	189	653.5	580.9	16.2
4"	520.5	449	50.8	97.6	111	162	131.6	189	702.9	631.4	18.9

## DELTA SDU45, SDU46

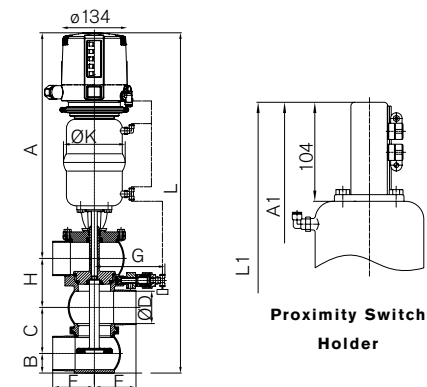

Valve with DELTA CU4

VALVE SIZE	A MM	A1 MM	C MM	B MM	ØD MM	F MM	G MM	H MM	ØK MM	L MM	L1 MM	WEIGHT KG
DN25	409	337	54	18	26	50	126	60	86	541	469	7
DN40	415	343	66	24	38	67	129	72	86	577	505	10
DN50	452	380	78	32	50	72	133	84	126	646	574	11
DN65	460.5	388	94	40	66	85	145	100	126	694.5	622	13
DN80	512.5	441	109	47.5	81	98	153	115	189	784	712.5	20
DN100	522.5	451	128	57	100	111	162	134	189	841.5	770	26
1"	407	335	50.6	16.3	22.6	50	126	56.6	86	530.5	458.5	7
1.5"	413	341	62.9	22.5	34.9	67	129	68.9	86	567.3	495.3	10
2"	451	379	75.6	30.8	47.6	72	133	81.6	126	639	567	11
2.5"	457.5	385	88.3	37.2	60.3	85	142	94.3	126	677.3	604.8	13
3"	508.5	436	100.9	43.5	72.9	90	148	106.9	189	759.8	687.3	20
4"	520.5	449	125.6	55.8	97.6	111	162	131.6	189	833.5	762	26

## DELTA SDT41, SDT42

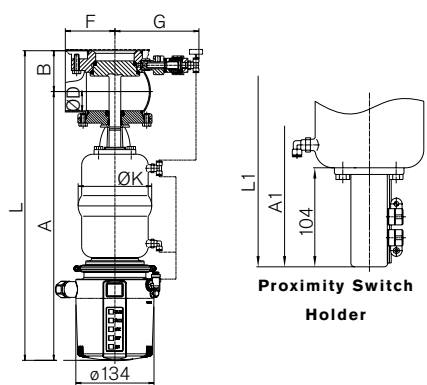

Valve with DELTA CU4

VALVE SIZE	A MM	A1 MM	B MM	ØD MM	F MM	G MM	ØK MM	L MM	L1 MM	WEIGHT KG
DN25	409	337	50	26	67	144	86	459	387	6
DN40	415	343	56	38	67	144	86	471	399	8
DN50	452	380	62	50	72	151	126	514	442	10
DN65	460.5	388	70	66	85	160	126	530.5	459	12
DN80	512.5	441	79.5	81	98	173.5	189	592	520	18
DN100	522.5	451	89	100	111	186.5	189	611.5	540	21
1"	407	335	48.3	22.6	67	144	86	455.3	383	6
1.5"	413	341	54.45	34.9	67	144	86	467.45	395	8
2"	451	379	60.9	47.6	72	151	126	511.9	440	10
2.5"	457.5	385	67.15	60.3	85	160	126	524.65	453	12
3"	508.5	436	73.05	72.9	90	165.5	189	581.55	510	18
4"	520.5	449	87.8	97.6	111	186.5	189	608.3	536	21

## Additional Technical Information

### MAX. HOLDING PRESSURES

VALVE SIZE	WITHOUT CONTROL UNIT			WITH NOT ELEMENT		
	DIAMETER, ACTUATOR			DIAMETER, ACTUATOR		
	74 MM	110 MM	165 MM	74 MM	110 MM	165 MM
DN25 / 1"	6.4 BAR	16.0 BAR	-	16.0 BAR	16.8 BAR	-
DN40 / 1,5"	3.6 BAR	9.6 BAR	-	12.4 BAR	17.6 BAR	-
DN50 / 2"	-	6.0 BAR	11.2 BAR	-	17.6 BAR	17.6 BAR
2,5"	-	4.7 BAR	11.6 BAR	-	14.0 BAR	16.0 BAR
DN65	-	3.5 BAR	9.3 BAR	-	10.5 BAR	17.6 BAR
3"	-	-	8.0 BAR	-	-	17.6 BAR
DN80	-	-	6.0 BAR	-	-	17.2 BAR
DN100 / 4"	-	-	4.4 BAR	-	-	12.8 BAR

### KVS VALUES

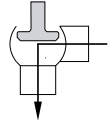
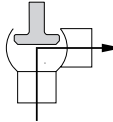
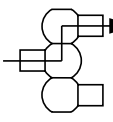
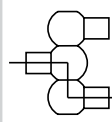
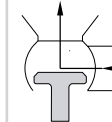
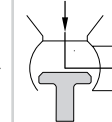
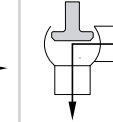
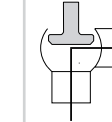
VALVE SIZE	SD41, SD42, SDE43, SDE44		SDU45, SDU46		SDT41, SDT42		SDMS41, SDMS42	
	M3/H							
								
DN25	19	20	19	14	19	20	22	22
DN40	42	39	42	33	42	39	42	38
DN50	88	70	88	58	88	70	73	70
DN65	145	120	145	100	145	120	120	112
DN80	175	190	175	160	175	190	170	160
DN100	220	265	220	245	220	265	325	276
1"	15	16	15	10	15	16	22	22
1.5"	39	26	39	30	39	26	42	38
2"	79	63	79	54	79	63	73	70
2.5"	124	106	124	87	124	106	120	112
3"	155	150	155	137	155	150	135	135
4"	215	258	215	225	215	258	325	276

# DELTA SD4

DOUBLE SEAL VALVES



## Global locations

### USA

#### SPX FLOW TECHNOLOGY

611 Sugar Creek Road  
Delavan, WI 53115  
USA  
+1-888 278 4321

### APAC

#### SPX FLOW TECHNOLOGY

25 International Business Park  
#03-03/12, German Centre  
Singapore 609916  
+65 6264 4366

### EMEA

#### SPX FLOW TECHNOLOGY

The Beehive, City Place  
Beehive Ring Road  
Gatwick, West Sussex RH6 0PA  
United Kingdom  
+44 (0) 1293 527 777

### ABOUT SPX

Based in Charlotte, North Carolina, SPX Corporation (NYSE: SPW) is a global multi-industry manufacturing leader. For more information, please visit [www.spx.com](http://www.spx.com).

### SPX FLOW TECHNOLOGY

Zechenstraße 49  
D-59425 Unna  
Germany  
Phone: +49(0) 23 03 / 108-0  
Fax: +49(0) 23 03 / 108-210

SPX reserves the right to incorporate our latest design and material changes without notice or obligation.

Design features, materials of construction and dimensional data, as described in this bulletin, are provided for your information only and should not be relied upon unless confirmed in writing. Please contact your local sales representative for product availability in your region. For more information visit [www.spx.com](http://www.spx.com).

The green ">" is a trademark of SPX Corporation, Inc.

APV-8042-GB Version: 02/2014 Issued: 09/2014 COPYRIGHT © 2012, 2014 SPX Corporation